

imanpack

PACKAGING & ECO SOLUTIONS

VICEVERSA

Manual Inclined Wrapping Machine

The small tilting packaging machine allows you to create packages of various lengths for different types of product thanks to the particular rotating unit comprising a sealing and forming unit.

This system guarantees multiple applications with horizontal, vertical and intermediate position product feed options. PLC managed operating parameters and programmes. The machine can also be equipped with a number of accessories upon request, such as printers, print centring photocells, European hole punch etc.

Max package length

Up to 1 metre

Min - Max package width

10 mm - 300 mm

Min - Max package height

10 mm - 180 mm

Film width

600 mm

Production speed

20-25 packages/min





TECHNICAL FEATURES

- Reel holder, forming unit and sealing units grouped together to form a single rotating unit.
- Adjustable forming tube.
- PLC managed operating parameters and production cycle programming.
- Touchscreen control keyboard.
- Possibility to add accessories upon request, such as printers, photocells, European hole punch and feeding and discharge systems.
- Machine weight: 300 kg.
- Installed power: 3 kW - 220 V - 1Ph.
- Machine built according to CE Standards.

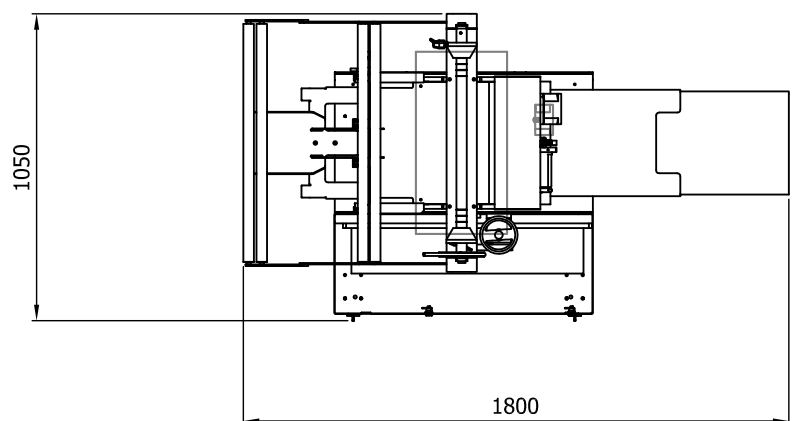
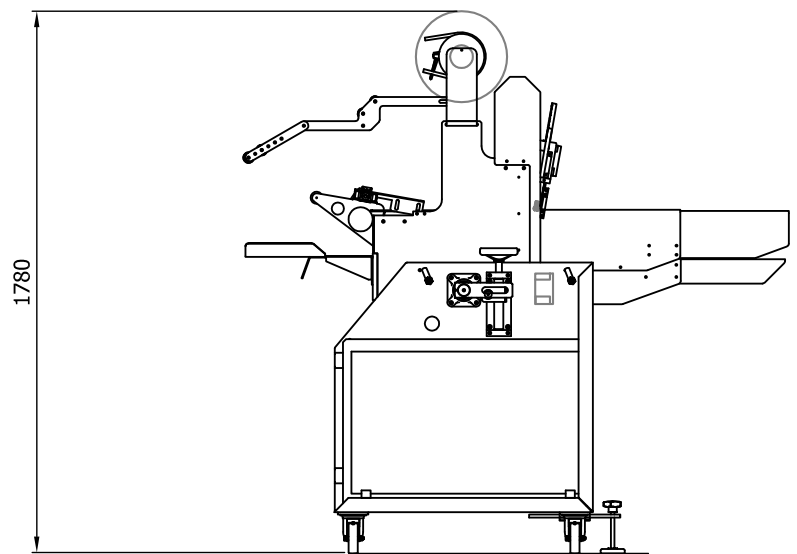

layout

imanpack

PACKAGING & ECO SOLUTIONS

Via Lago di Bolsena, 19 36015 Schio (VI) ITALY
Tel. +39.0445.578.811 Fax+39.0445.575.111
www.imanpack.it email: info@imanpack.it