

imanpack

PACKAGING & ECO SOLUTIONS

MOONLIGHT PBB MULTIPACK

Flow-wrapper (HFFS)

Horizontal wrapping machine with extended sealing time and 4-axis electronic control. It is available in different versions, for polyethylene film or heat sealing materials, with reel loaded from top or bottom and in a stainless steel version.



Product range

Length: from 50 to 800 mm

Width: from 20 to 380 mm

Height: up to 200 mm



TECHNICAL FEATURES

- Stainless steel structure.
- 2800 mm infeed conveyor belt.
- Transversal sealing unit with 400 mm sealing spatulas.
- Universal forming unit adjustable using a hand-wheel.
- Reel holder from below for reels up to 900 mm wide.
- Movement axes control via four brushless motors for:
 - Transversal sealing unit
 - Longitudinal sealing wheels
 - Conveyor belt below the sealing wheels
 - Feeder conveyor belt
- Longitudinal sealing unit adjustable in height.
- Transversal sealing unit adjustable in height.
- Cutting-sealing unit with handle maker device.
- Control panel on machine frame.
- Machine built according to CE standard.

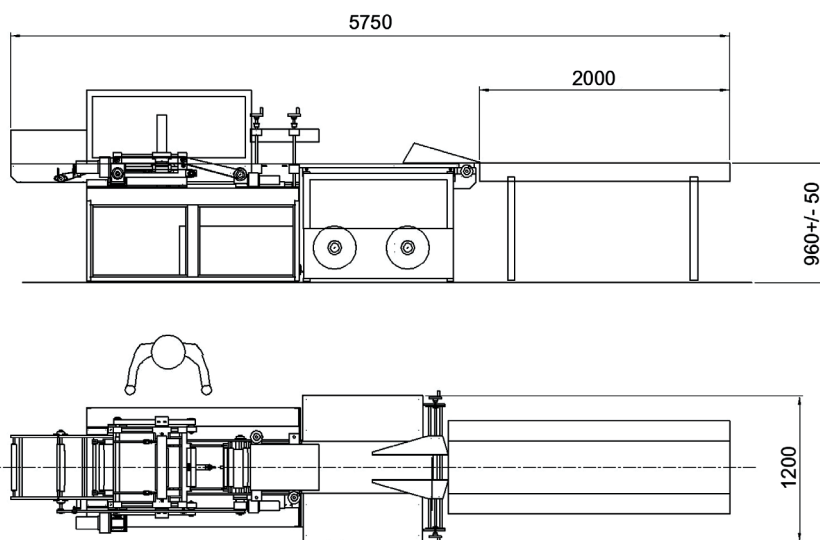

layout

imanpack

PACKAGING & ECO SOLUTIONS

Via Lago di Bolsena, 19 36015 Schio (VI) ITALY
Tel. +39.0445.578.811 Fax+39.0445.575.111
www.imanpack.it email: info@imanpack.it

ACCESSORIES

- Automatic feeding.
- UVC lamps for film sterilization.
- Gas injection.
- Oxygen residual continuous analyzer.
- Mechanical bellows.
- Labelling systems.
- Print-on-film systems.
- Wire cutting and film trimming device.