

imanpack

PACKAGING & ECO SOLUTIONS

MICROPAC PRO

Flow-wrapper (HFFS)

Rotary flow-wrapper suitable for wrapping solid products in general using heat sealing or polyethylene film. Control and command via PLC.

Can be connected to automated production lines.



Product Range

Width: up to 180 mm

Length: from 20 mm

Height: up to 150 mm

Speed

Up to 250 bags/min



TECHNICAL FEATURES

- Mainframe in painted steel.
- Paddle wheel conveyor belt 1500 mm long in AISI 304 steel.
- Food grade plastic rapid extraction product pushers.
- Electronic pitch adjustment.
- Reel holder from above with electronic opening for reels up to 500 mm wide.
- Electronic torque limiter.
- Longitudinal sealing unit with pre-heated drive wheel, heat sealing wheel and flap folding wheel.
- Rotary cross sealing unit with 200 mm sealing jaw, with electronic thermoregulator control.
- Brushless motors for:
 - Conveyor belt
 - Longitudinal sealing unit
 - Cross sealing unit
- Universal adjustable forming unit.
- Output conveyor belt, 1000 mm long.
- 7" touch-screen control panel.
- Plastic material incident guards with safety micro switch.
- Integrated electrical system detached from any mechanical parts.
- Machine built according to CE Standards.

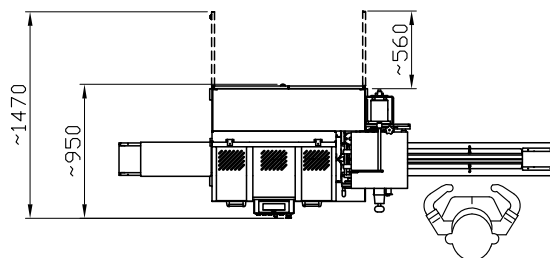
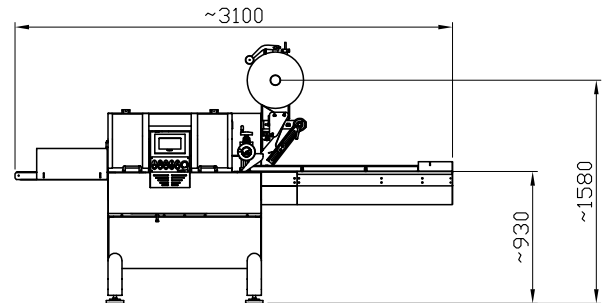

layout

ACCESSORIES

- Full AISI 304 inox version.
- Automatic loaders.
- Different conveyor belt lengths.
- Motorized reel unwinder with inverter.
- Printers and labellers.
- Motorized output conveyor belt with inverter.
- "No product - no bag" system.

imanpack

PACKAGING & ECO SOLUTIONS

Via Lago di Bolsena, 19 36015 Schio (VI) ITALY
Tel. +39.0445.578.811 Fax+39.0445.575.111
www.imanpack.it email: info@imanpack.it