

imanpack

PACKAGING & ECO SOLUTIONS

MCWS 9

Piece counting/weighing machine

Piece counting/weighing machine particularly indicated for weighing small and medium size hardware such as nails, screws, nuts, bolts, plastic, aluminium casts and miscellaneous small parts. The micro-processor constantly monitors the weighing system to guarantee the set dose at maximum speed.



Weighing range

From 50 g to 2 kg

Product range

Small and medium size small parts, hardware

Maximum product length

80 mm

Speed

Up to 15 cycles/min

Weighing basket sensitivity

0.2 g





TECHNICAL FEATURES

- Torsional vibrator with 600 mm diameter and two outlets, one for roughing and one for finishing processes.
- Weighing basket with pneumatic opening.
- Finishing belt with counting photocell.
- Possibility of using the machine as a piece counter only, to meet specific requirements.
- Possibility of memorising different programmes to suit various products.
- Possibility of linking it to other machines (bags, sacks, boxes, KLT).
- Machine built according to CE Standards.

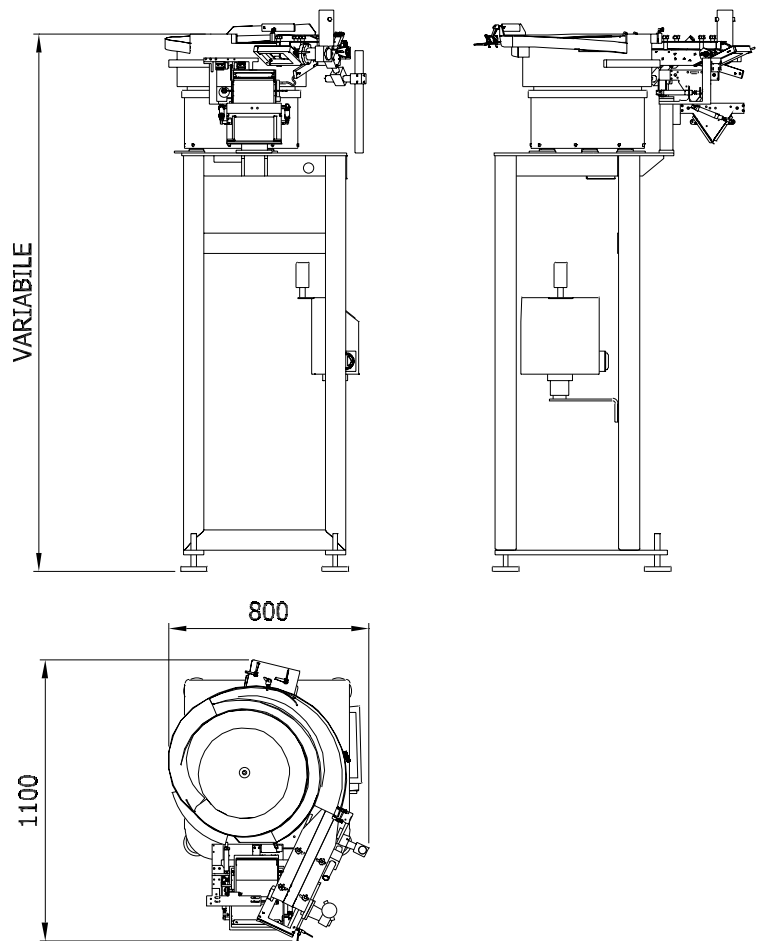

layout

imanpack

PACKAGING & ECO SOLUTIONS

Via Lago di Bolsena, 19 36015 Schio (VI) ITALY
Tel. +39.0445.578.811 Fax+39.0445.575.111
www.imanpack.it email: info@imanpack.it