

imanpack

PACKAGING & ECO SOLUTIONS

MCWS 16/24

Piece counting/weighing machine

Piece counting/weighing machine particularly indicated for weighing small and medium size hardware such as nails, screws, nuts, bolts, plastic, aluminium casts and miscellaneous small parts. The micro-processor constantly monitors the weighing system to guarantee the set dose at maximum speed.

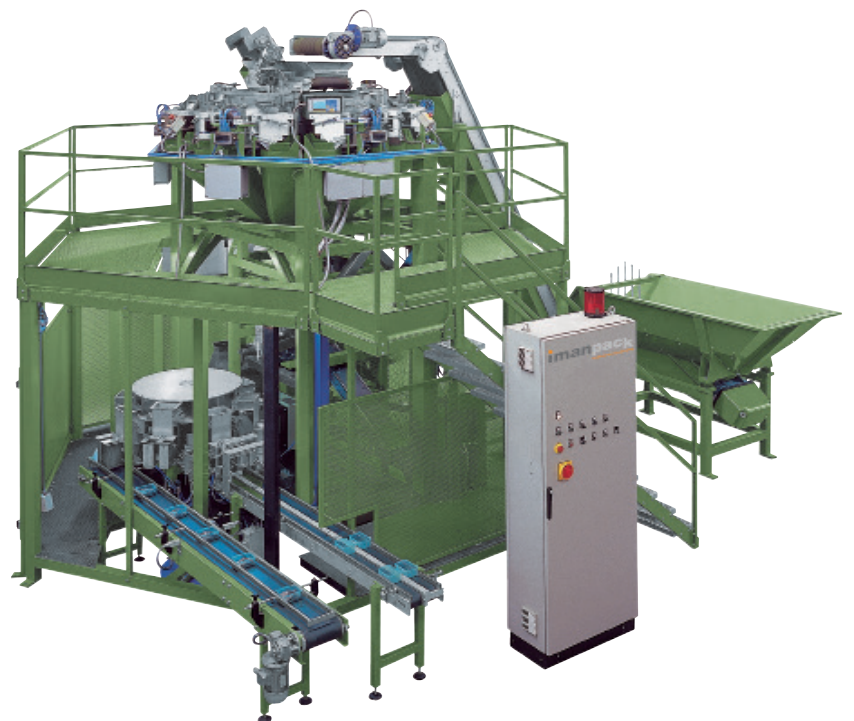

Weighing range

From 0.2 g to 1 kg

Product range

Small and medium size small parts, hardware

Maximum product length

100 mm

Speed

Up to 35 cycles/min

Weighing basket sensitivity

0,5 g





TECHNICAL FEATURES

- System with 4 or 6 torsional vibrators with 600 mm diameter and 2 outlets.
- Multiple weighing system (8-12 load cells).
- Synchronism baskets (8-12) to accelerate production rates.
- Reject basket to eliminate doses outside the tolerance range.
- The system automatically combines the weight of the various baskets to achieve the required dose.
- Possibility of memorising different programmes to suit various products.
- Possibility of linking it to other machines (bags, sacks, boxes, KLT).
- Machine built according to CE Standards.

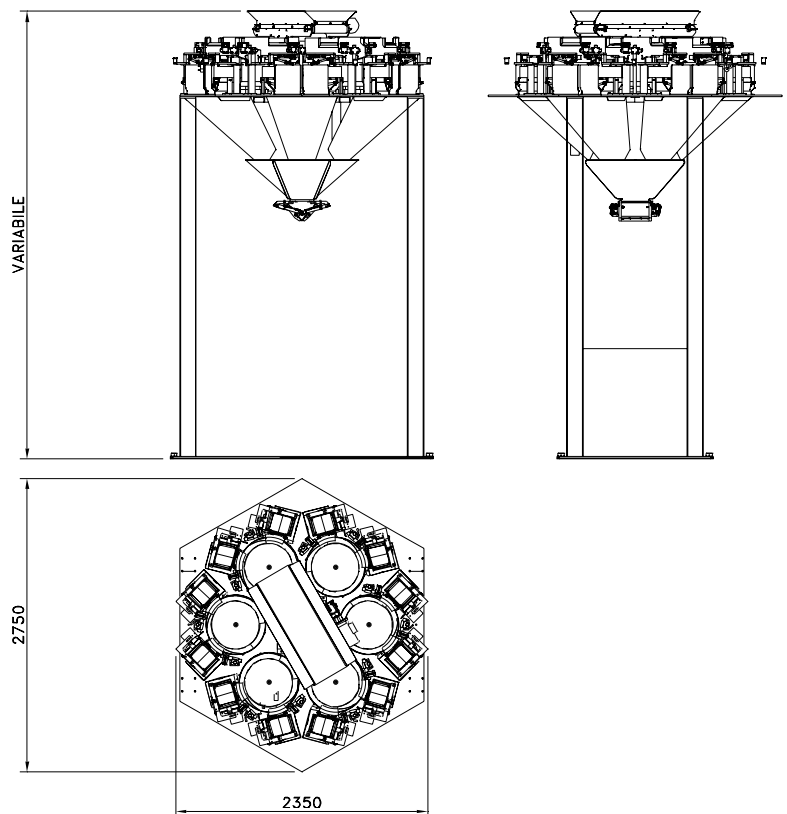

layout

imanpack

PACKAGING & ECO SOLUTIONS

Via Lago di Bolsena, 19 36015 Schio (VI) ITALY
Tel. +39.0445.578.811 Fax+39.0445.575.111
www.imanpack.it email: info@imanpack.it